

REPAIR PARTS MANUAL
MODEL NO. M11597 (96011023406)
Lawn Tractor



McCULLOCH

www.mcculloch.biz

HOW TO USE THIS MANUAL

This manual is designed to provide the customer with a means to identify the parts on his/her tractor when ordering repair parts. The illustrations may or may not represent the actual assemblies; therefore, it is not recommended to use this manual as a guide to assemble or disassemble the tractor. Some hardware and parts are drawn larger in order to more readily identify them.

Each tractor has its own model number.

The model number for your tractor can be found on the fender under the seat.

When ordering parts, always give the following information:

- Product - "Tractor"
- Model Number - "M11597 96011023406"
- Part Number
- Part Description

TABLE OF CONTENTS

SCHEMATIC	3
ELECTRICAL.....	4-5
CHASSIS	6-7
DRIVE.....	8-9
STEERING	10-11
ENGINE.....	12-13
SEAT	14
DECALS.....	15
MOWER DECK.....	16-17
MOWER LIFT.....	18

TRACTOR - MODEL NUMBER M11597 (96011023406), PRODUCT NO. 960 11 02-34 SCHEMATIC

SCH01

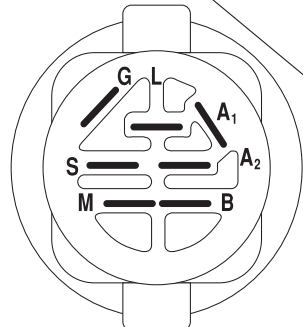
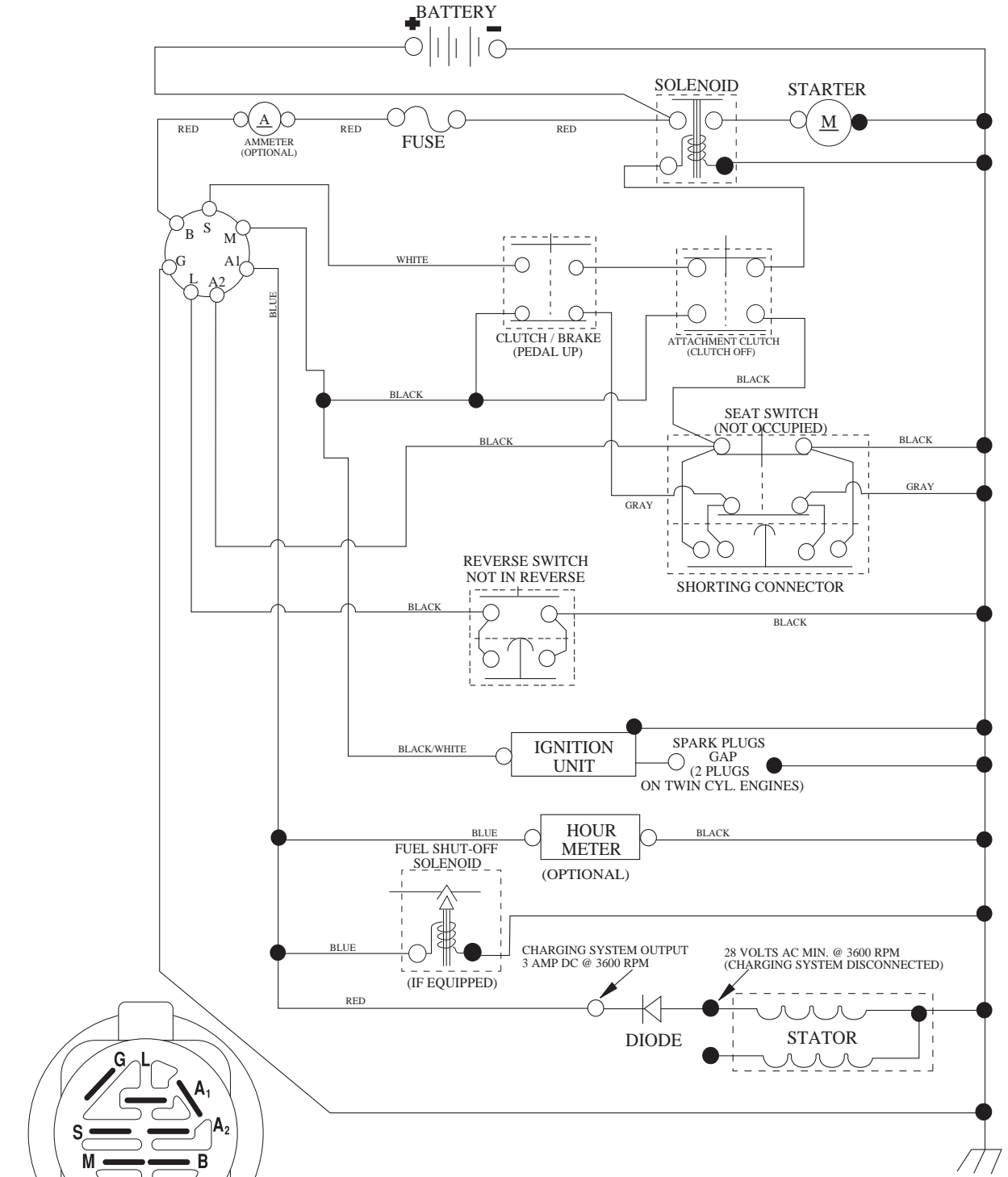

IGNITION SWITCH

POSITION	CIRCUIT "MAKE"
OFF	M+G+A1
RUN/OVERRIDE	B+A1
RUN	B+A1 L+A2
START	B + S + A1

WIRING INSULATED CLIPS
NOTE: IF WIRING INSULATED CLIPS WERE REMOVED FOR SERVICING OF UNIT, THEY SHOULD BE RE-INSTALLED TO PROPERLY SECURE YOUR WIRING.

○
REMOVABLE CONNECTIONS

●
NON-REMOVABLE CONNECTIONS

REPAIR PARTS

TRACTOR - MODEL NUMBER M11597 (96011023406), PRODUCT NO. 960 11 02-34
ELECTRICAL

KEY NO.	PART NO.	DESCRIPTION
1	532 14 49-24	Battery 20 Amp
2	874 76 04-12	Bolt Hex Hd 1/4-20 Unc x 3/4
8	532 17 66-89	Battery Box
16	532 17 61-38	Switch Interlock Push-In
24	532 42 12-99	Cable Battery 6 Ga. 11"red
25	532 42 12-97	Cable Battery
26	532 17 51-58	Fuse
27	873 51 04-00	Nut Keps Hex 1/4-20 unc
28	532 42 12-98	Cable Ground 6 Ga. 12"black
29	532 19 27-49	Switch Seat
30	532 19 33-50	Switch Ign
33	532 41 19-35	Key/Chain
40	532 19 74-27	Harness Ign
41	871 11 04-08	Bolt Blk Fin Hex 1/4-20
42	532 13 15-63	Cover Terminal Red
43	532 19 25-07	Solenoid
55	817 00 06-12	Screw 3/8-16 x 3/4
90	532 18 04-49	Cover Terminal Battery
92	532 19 66-15	Harness Pigtail Consls ROS
93	532 19 25-40	Screw Plastite 10-14 x 2.0
94	532 19 18-34	Module Reverse ROS

NOTE: All component dimensions given in U. S. inches
1 inch = 25.4 mm.

REPAIR PARTS

TRACTOR - MODEL NUMBER M11597 (96011023406), PRODUCT NO. 960 11 02-34
CHASSIS AND ENCLOSURES

KEY NO.	PART NO.	DESCRIPTION
1	532 17 46-20	Chassis
2	532 17 65-54	Drawbar
5	532 15 52-72	Bumper, Hood/Dash
6	532 18 44-19	Saddle
8	532 15 51-38	Clip, Retainer
9	532 19 46-88	Dash
10	872 14 06-08	Bolt, Carriage 3/8-16 x 1
11	532 17 49-96	Panel Dash LH
13	532 18 17-19	Panel, Silkscr Dash RH
15	874 18 05-12	Screw 5/16-18 x 3/4
16	873 51 05-00	Nut Keps 5/16-18 x 3/4
17	532 40 61-79	Hood
18	532 18 49-21	Bumper Hood
24	874 78 06-16	Bolt Fin Hex 3/8-16 unc x 1 Gr. 5
25	819 13 13-12	Washer 13/32 x 13/16 x 12 Ga.
26	873 80 06-00	Nut Lock Hex w/Ins 3/8-16 unc
28	532 19 47-98	Grille
30	532 40 48-52	Fender
31	532 13 66-19	Bracket Fender Repl 109873x
33	532 18 25-07	Footrest Pnt LH
34	532 18 25-08	Footrest Pnt RH
35	872 11 06-06	Bolt Rdhd Sht Sqnk 3/8-16 x 3/4
37	817 49 05-08	Screw Thdrol 5/16-18 x 1/2 TYT
38	532 17 57-10	Bracket Asm. Pivot Mower Rear
39	532 18 75-68	Bracket Pivot
141	873 90 06-00	Nut Lock Flg 3/8-16 unc
145	532 40 91-67	Rod Pivot Chassis/Hood
152	817 72 04-08	Screw THd Cut 1/4-20 x 1/2
205	817 49 06-08	Screw Thdrol 3/8-16 x 1/2
208	817 67 06-08	Screw Thdrol 3/8-16 x 1/2
209	817 00 06-12	Screw Hex Wsh Thdrol 3/8-16
278	532 41 63-58	Screw 10 x .750 BOS Thread
310	532 42 27-66	Shield Lower RH
311	532 42 27-67	Shield Lower LH
313	532 19 66-88	Clips Threaded
314	532 13 77-29	Screw Thd Roll 1/4-20 x 5/8
315	532 42 27-71	Shield Upper RH
316	532 42 27-72	Shield Upper LH
317	532 42 28-60	Shield Rear
--	532 19 39-35	Plug Switch Light
--	532 00 54-79	Plug Button Blk 359 Dia Choke

NOTE: All component dimensions given in U.S. inches
1 inch = 25.4 mm.

REPAIR PARTS

TRACTOR - MODEL NUMBER M11597 (96011023406), PRODUCT NO. 960 11 02-34
DRIVE

KEY NO.	PART NO.	DESCRIPTION	KEY NO.	PART NO.	DESCRIPTION
1	-----	Transaxle, Peerless 204-544C (Order parts from transaxle manufacturer)	65	810 04 07-00	Washer Lock Hvy Hlcl Spr 7/16
2	532 14 66-82	Spring Return Brake T/a Zinc	66	532 15 47-78	Keeper Belt Engine Foolproof
3	532 12 36-66	Pulley Transaxle 18" tires	69	532 14 24-32	Screw Hex Wsh Hi-Lo 1/4 x 1/2 unc
4	812 00 00-28	Ring Retainer # 5100-62	70	532 13 46-83	Guide Belt Mower Drive RH
5	532 12 15-20	Strap Torque 30 Degrees	74	532 13 70-57	Spacer Axle
6	817 06 05-12	Screw 5/16-18 x 3/4	75	532 12 17-49	Washer 25/32 x 1 1/4 x 16 Ga
8	532 19 27-06	Rod Shifter	76	812 00 00-01	E-ring #5133-75
10	876 02 04-16	Pin Cotter 1/8 x 1 Cad	77	532 12 35-83	Key Square 2 0 x 1845/ 1865
11	532 10 57-01	Washer Plate Shf 388 Sq Hole	78	532 12 17-48	Washer 25/32 x 1-5/8 x 16 Ga
13	874 55 04-12	Bolt 1/4-28 Unf Gr 8 W/Patch	79	532 12 50-96	Key Woodruff
14	810 04 04-00	Washer Lock Hvy Helical 1/4	80	532 13 14-86	Arm Shift Transaxle
15	874 49 05-44	Bolt Hex Flghd 5/16-18 Gr. 5	81	532 16 55-94	Shaft Asm. Cross Taper
16	873 80 05-00	Nut Lock Hx W/Ins 5/16-18 Unc	82	532 16 57-11	Spring Torsion Shift
18	874 78 06-16	Bolt, Fin Hex 3/8-16 Unc x 1 Gr. 5	83	819 17 12-16	Washer 17/32 x 3/4 x 16 Ga.
19	873 80 06-00	Nut Lock 3/8-16 Unc	84	532 16 62-28	Link Transaxle
21	532 10 69-33	Knob	85	532 15 03-60	Nut Lock Center 1/4-28
22	532 13 08-04	Rod Brake Blk Zinc 26 840	89	532 19 58-61	Console, SVC Shift
24	873 35 06-00	Nut Hex Jam 3/8-16 Unc	96	532 12 47-88	Retainer Spring 1"
25	532 10 68-88	Spring Rod Brake 2 00 Zinc	112	819 09 12-10	Washer 9/32 x 3/4 x 10 Ga.
26	819 13 13-16	Washer 13/32 x 13/16 x 16 Ga	113	532 12 72-85	Strap Torque Lh
27	876 02 04-12	Pin Cotter 1/8 x 3/4 Cad	116	872 14 06-08	Bolt Rdhd Sq Neck 3/8-16 x 1.00
28	532 17 57-65	Rod Brake Parking	120	873 90 06-00	Nut Lock Flg 3/8-16
29	532 07 16-73	Cap Brake Parking	150	532 17 54-56	Spacer Retainer
30	532 17 49-73	Bracket Mtg Transaxle	151	819 13 32-10	Washer 13/32 x 2 x 10
32	874 76 05-12	Bolt Hex Hd 5/16-18unc x 3/4	156	532 16 60-02	Washer Srrtd 5/16ID x 1.0 x .125TK
34	532 17 55-78	Shaft Asm Pedal Foot	158	532 16 55-89	Bracket Shift Mount
35	532 12 01-83	Bearing Nylon Blk 629 Id	159	532 18 39-00	Hub Shift
36	819 21 16-16	Washer 21/32 x 1 x 16 Ga	161	872 14 04-06	Bolt RDHD SQNK 1/4-20 x 3/4 Gr.5
37	532 12 49-63	Pin Roll 3/16 x 1"	162	873 68 04-00	Nut Crownlock 1/4-20 UNC
38	532 17 91-14	Pulley Idler Composite	163	874 78 04-16	Bolt Hex Fin 1/4-20 UNC x 1 Gr.5
39	872 11 06-22	Bolt Rdhd 3/8-16 Unc x 2-3/4 Gr. 5	165	532 16 56-23	Bracket Pivot Lever
41	532 17 55-56	Keeper Belt Retainer Idler	166	817 49 05-10	Screw 5/16-18 x 5/8 TT Yellow
47	532 12 77-83	Pulley Idler V Groove Plastic	168	532 16 54-92	Shoulder Bolt 5/16 -18 x .561
48	532 15 44-07	Bellcrank Asm	169	532 16 55-81	Plate, Fastening
49	532 12 32-05	Retainer Belt Style Spring	170	532 18 74-14	Keeper Belt T/A
50	872 11 06-12	Bolt Carr Sh 3/8-16 x 1-1/2 Gr. 5	197	532 16 96-13	Nyliner Snap-in 5/8" ID
51	873 68 06-00	Nut Crownlock 3/8-16 Unc	198	532 16 98-45	Washer Nyl
52	873 68 05-00	Nut Crownlock 5/16-18 Unc	202	872 11 06-14	Bolt, 3/8 - 16 x 1-3/4 Gr. 5
53	532 19 96-52	Link Clutch	212	532 14 52-12	Nut Flange Hex Lock
55	532 10 57-09	Spring Return Clutch 6 75	263	817 00 06-12	Screw, 3/8-16 x 3/4
56	817 06 06-20	Screw 3/8-16 x 1-1/4	268	532 18 24-02	Guard, Muffler
57	532 13 82-55	V-Belt Ground Drive	275	819 13 16-14	Washer, 13/32 x 1 x 14 Ga.
62	532 12 48-72	Cover Pedal Blk Round			
63	532 17 54-10	Engine Pulley			
64	532 17 39-37	Bolt Hex			

NOTE: All component dimensions given in U.S. inches
1 inch = 25.4 mm

REPAIR PARTS

TRACTOR - MODEL NUMBER M11597 (96011023406), PRODUCT NO. 960 11 02-34
STEERING

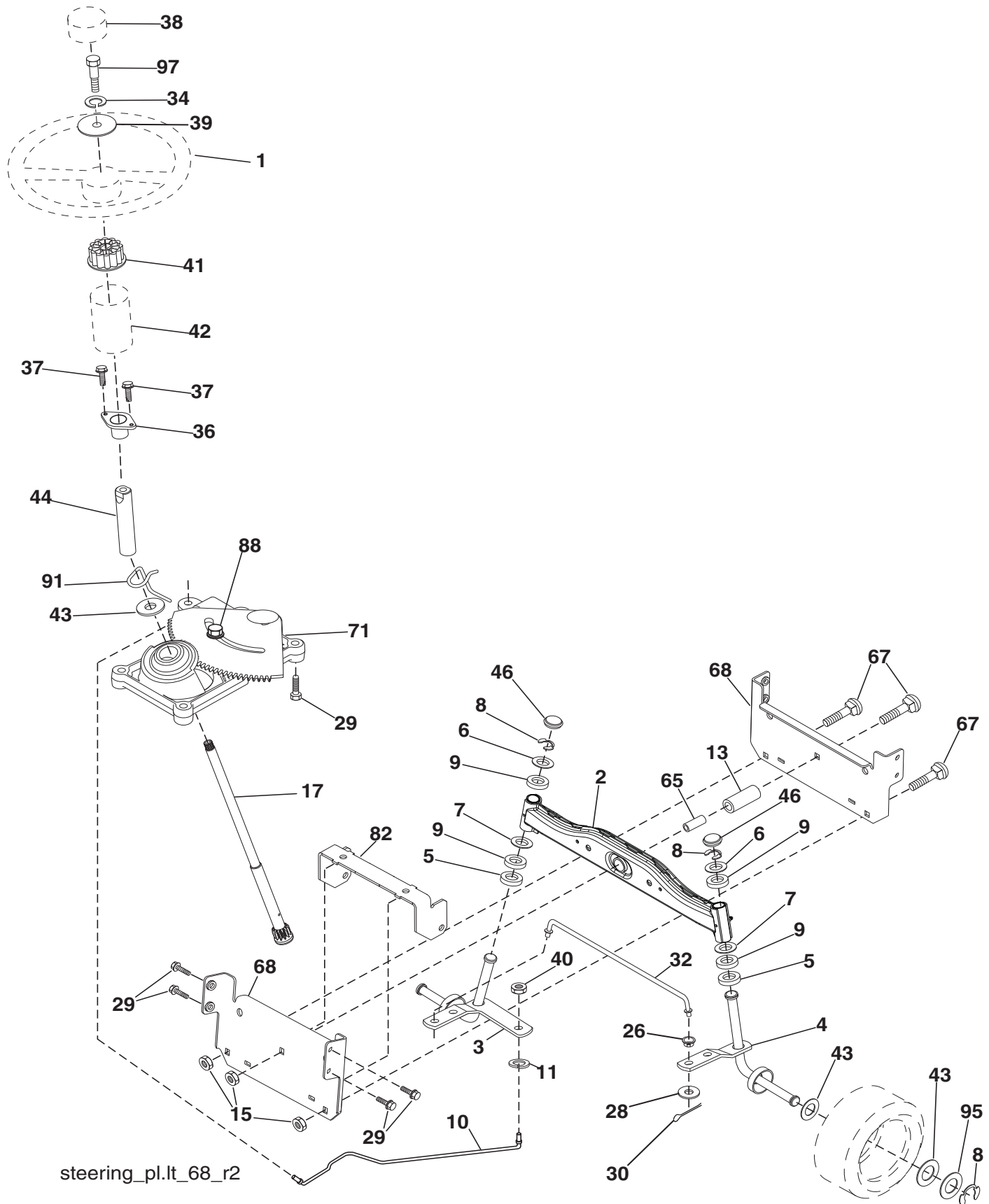

REPAIR PARTS

TRACTOR - MODEL NUMBER M11597 (96011023406), PRODUCT NO. 960 11 02-34
STEERING

KEY NO.	PART NO.	DESCRIPTION
1	532 18 67-80	Wheel Steering
2	532 41 81-68	Axle Asm
3	532 16 98-40	Spindle Asm LH
4	532 16 98-39	Spindle Asm RH
5	532 12 49-31	Washer Thrust
6	532 12 17-48	Washer 25/32 x 1-5/8 x 16 Ga.
7	819 27 20-16	Washer 27/32 x 1-1/4 x 16 Ga.
8	812 00 00-29	Ring Klip #t5304-75
9	532 12 49-37	Bearing Col Strg Blk
10	532 17 51-21	Link Drag
11	810 04 06-00	Washer Lock Hvy Hlcl Spr 3/8
13	532 13 65-18	Spacer earing Axle Front
15	532 14 52-12	Hexflange Lock
17	532 19 07-53	Shaft Asm Strg
26	532 12 68-47	Bushing Link Drag Blk LR
28	819 13 14-16	Washer 13/32 x 7/8 x 16 Ga.
29	817 00 06-12	Screw 3/8-16 x 3/4
30	876 02 04-12	Pin Cotter 1/8 x 3/4 Cad
32	532 19 27-57	Rod Tie Wire Form 19 75 Mech
34	810 04 05-00	Washer Lock 5/16
36	532 15 50-99	Bushing Strg 5/8 Id Dash
37	532 15 29-27	Screw
38	532 19 29-16	Cap Wheel Steer
39	819 11 38-12	Washer 11/32 ID x 2 3/8 OD x 12 Ga.
40	873 54 06-00	Nut Crownlock 3/8-24
41	532 18 67-37	Adaptor Wheel Strg
42	532 16 96-33	Boot Steering
43	532 12 17-49	Washer 25/32 x 1 1/4 x 16 Ga.
44	532 19 07-52	Extension Steering
46	532 12 12-32	Cap Spindle Fr Top Blk
65	532 41 47-36	Spacer Brace Axle
67	872 11 06-18	Bolt RdHd Sqnk 3/8-16 x 2-1/4
68	532 16 98-27	Brace Axle
71	532 17 51-46	Steering Asm
82	532 19 99-78	Bracket Susp Chassis Front
88	532 17 51-18	Bolt shoulder 7/16-20
91	532 17 55-53	Clip Steering
95	532 18 89-67	Washer Hardened
97	874 78 05-64	Bolt 5/16-18 unc x 4" L Gr. 5

NOTE: All component dimensions given in U.S. inches
1 inch = 25.4 mm.

REPAIR PARTS

TRACTOR - MODEL NUMBER M11597 (96011023406), PRODUCT NO. 960 11 02-34
ENGINE

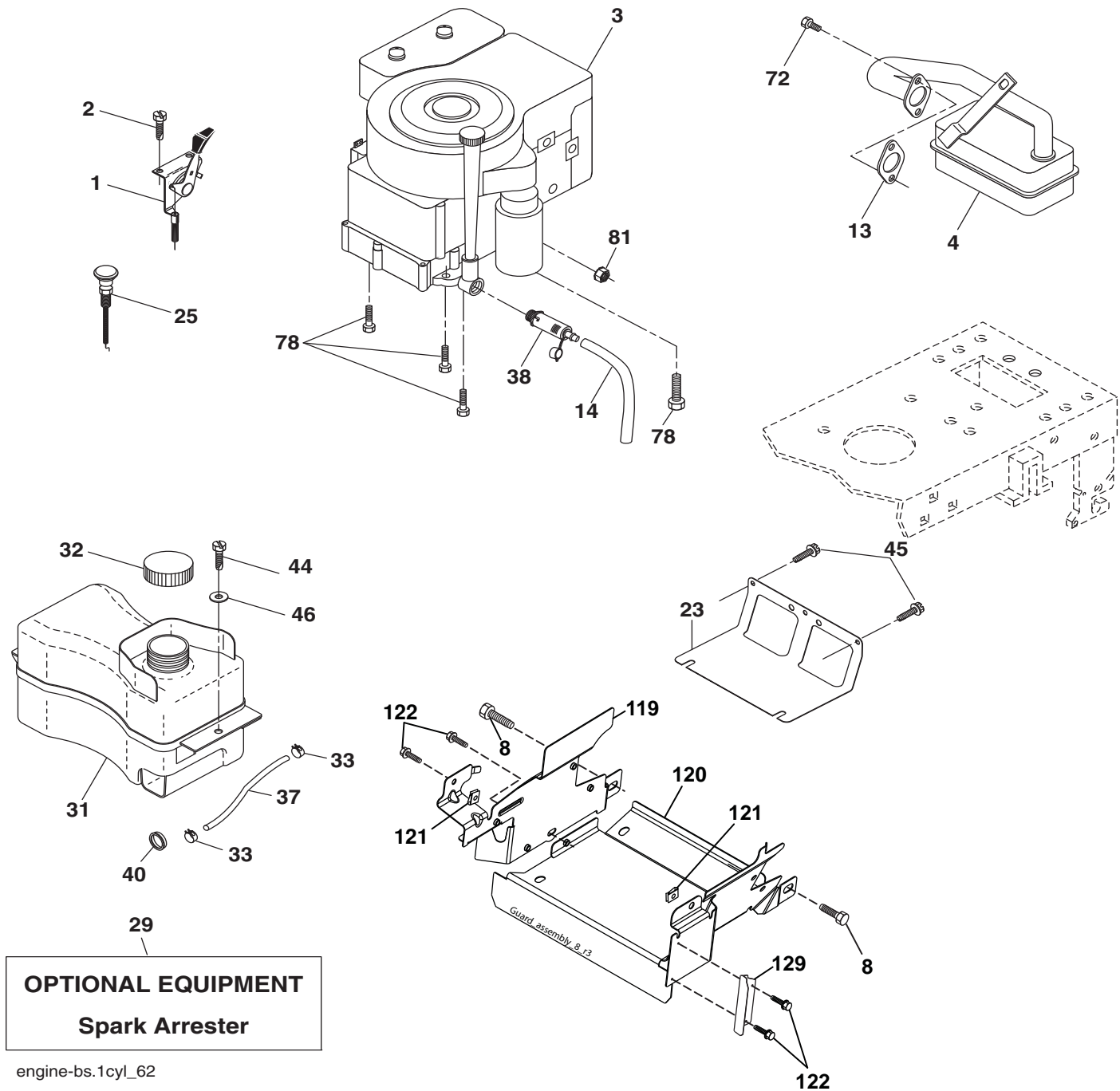

OPTIONAL EQUIPMENT
Spark Arrester

engine-bs.1cyl_62

REPAIR PARTS

TRACTOR - MODEL NUMBER M11597 (96011023406), PRODUCT NO. 960 11 02-34
ENGINE

KEY NO.	PART NO.	DESCRIPTION
1	532 17 05-51	Control Throttle / Choke
2	817 72 04-08	Screw Hex Thd Cut 1/4-20 x 5/8 T
3	-----	Engine Briggs Model 217807 (Order Parts from Engine Manufacturer)
4	532 17 97-58	Muffler Exhaust
8	532 17 18-77	Bolt 5/16 - 18 unc x 3/4
13	532 16 52-91	Gasket
14	532 14 84-56	Tube Drain Oil Easy
23	532 16 98-37	Shield Browning/Debris Guard
25	532 19 06-95	Control, Choke
29	532 13 71-80	Arrester Spark
31	532 40 75-16	Tank Fuel
32	532 42 51-62	Cap Fuel
33	532 12 34-87	Clamp Hose Blk
37	532 13 70-40	Line Fuel 20"
38	532 18 16-54	Plug Drain Oil Easy
40	532 12 40-28	Bushing Snap
44	817 67 04-12	Screw Hexwsh Thdrol 3/8-16 x 3/4
45	817 00 06-12	Screw 3/8-16 x 3/4
46	819 09 14-16	Washer 9/32 x 7/8 x 16 Ga.
72	532 19 23-34	Screw Socket Hd 5-16-18 x .75
78	817 06 06-20	Screw 3/8-16 x 1-1/4
81	873 51 04-00	Nut Keps Hex 1/4-20 unc
119	532 19 79-49	Guard Pulley Eng. LH
120	532 19 79-48	Guard Pulley Eng. RH
121	532 19 66-88	Clips Threaded
122	532 13 77-29	Screw 1/4 - 20 x 5/8
129	532 40 03-28	Guard Pulley Eng. Adapter

NOTE: All component dimensions given in U.S. inches
1 inch = 25.4 mm

Engine Power Rating Information

The gross power rating for individual gas engine models is labeled in accordance with SAE (Society of Automotive Engineers) code J1940 (Small Engine Power & Torque Rating Procedure), and rating performance has been obtained and corrected in accordance with SAE J1995 (Revision 2002-05). Torque values are derived at 3060 RPM; horsepower values are derived at 3600 RPM. Actual gross engine power will be lower and is affected by, among other things, ambient operating conditions and engine-to-engine variability. Given both the wide array of products on which engines are placed and the variety of environmental issues applicable to operating the equipment, the gas engine will not develop the rated gross power when used in a given piece of power equipment (actual "on-site" or net power). This difference is due to a variety of factors including, but not limited to, accessories (air cleaner, exhaust, charging, cooling, carburetor, fuel pump, etc.), application limitations, ambient operating conditions (temperature, humidity, altitude), and engine-to-engine variability. Due to manufacturing and capacity limitations, Briggs & Stratton may substitute an engine of higher rated power for this Series engine.

REPAIR PARTS

TRACTOR - MODEL NUMBER M11597 (96011023406), PRODUCT NO. 960 11 02-34
SEAT

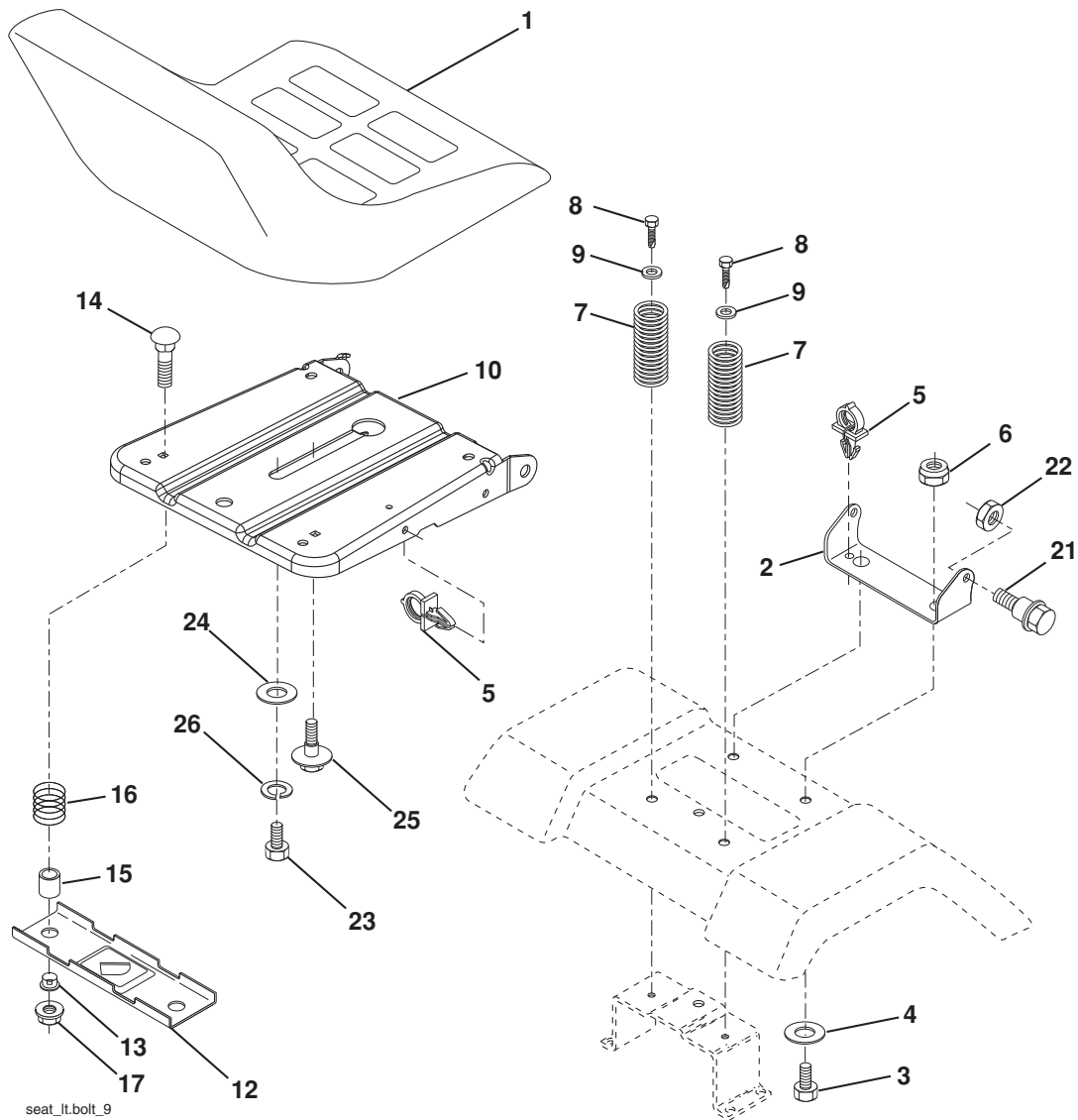

seat_lt.bolt_9

KEY NO.	PART NO.	DESCRIPTION
1	532 40 10-42	Seat
2	532 14 05-51	Bracket Seat Pivot
3	871 11 06-16	Bolt Hex 3/8 - 16 x 1
4	819 13 16-10	Washer 3/32 x 1 x 10 Ga.
5	532 14 50-06	Clip Push-In Hinged
6	873 80 06-00	Nut Lock Hex w/Ins 3/8 - 16
7	532 12 41-81	Spring Seat Cprsn 2 250 Blk Zi
8	817 00 06-16	Screw 3/8-16 x 1.5
9	819 13 16-14	Washer 13/32 x 1 x 14 Ga.
10	532 19 55-30	Pan Pnt Seat (Blk)
12	532 17 46-48	Bracket Pnt Mounting Switch
13	532 12 12-48	Bushing Snap Blk Nyl

KEY NO.	PART NO.	DESCRIPTION
14	872 05 04-12	Bolt Rdhd Sht Nk 1/4 - 20 x 1 -1/2
15	532 13 43-00	Spacer Split .28 x .96
16	532 12 12-50	Spring Cprsn
17	532 12 39-76	Nut Lock 1/4 Lge Flg
21	532 17 18-52	Bolt Shoulder 5/16-18 unc-2A
22	873 80 05-00	Nut Lock Hex w/Ins 5/16 - 18
23	871 11 08-14	Bolt Hex Black
24	819 17 19-12	Washer 17/32 x 1-3/16 x 12 Ga.
25	532 12 70-18	Bolt Shoulder 5/16-18 x .62
26	810 04 08-00	Washer Lock

NOTE: All component dimensions given in U.S. inches
1 inch = 25.4 mm.

REPAIR PARTS

TRACTOR - MODEL NUMBER M11597 (96011023406), PRODUCT NO. 960 11 02-34
DECALS

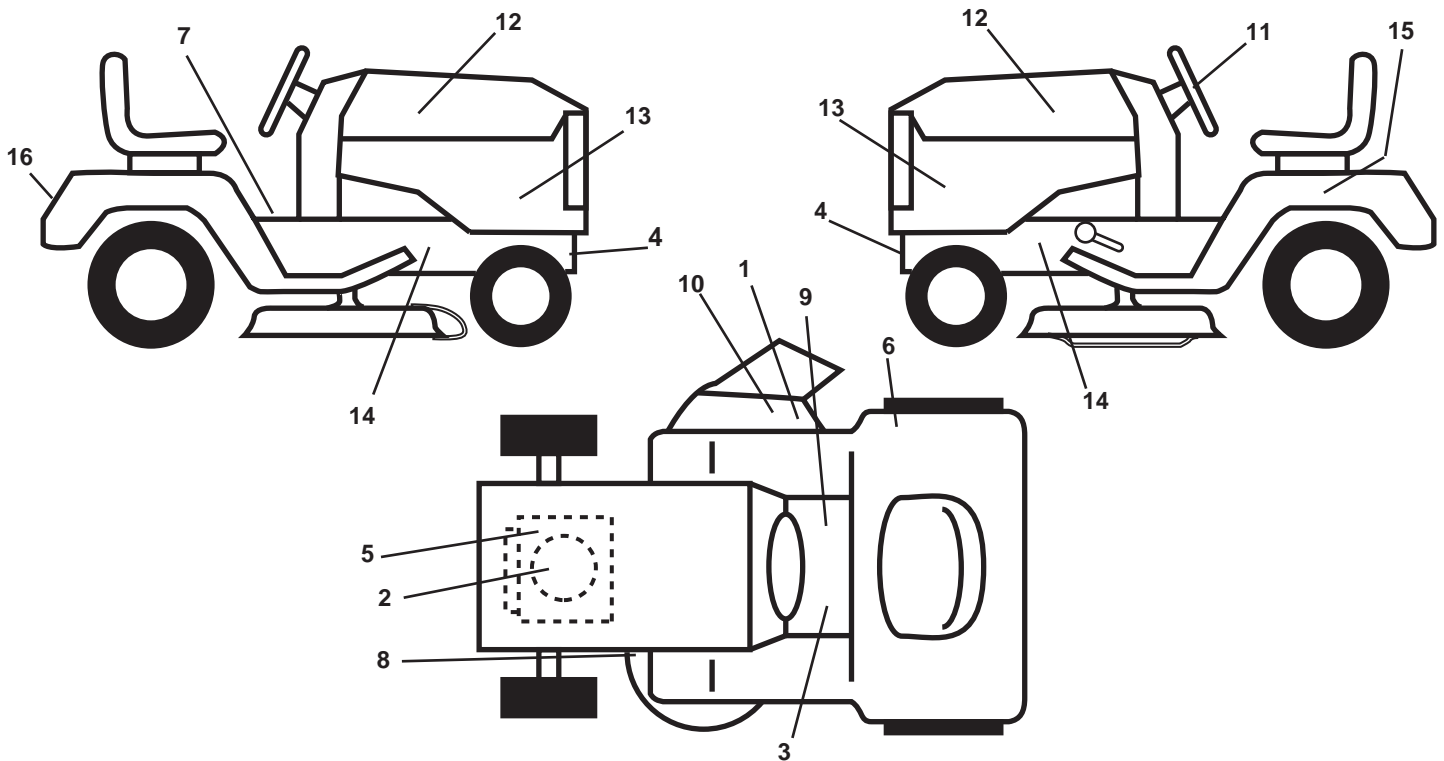

KEY NO.	PART NO.	DESCRIPTION
1	532 19 63-57	Decal, Deflect Wrn Cutting Finger Sym
2	532 41 79-25	Decal Engine HP
3	532 15 97-37	Decal, Brake/Clutch
4	532 15 97-36	Decal, Hot Muffler
5	532 19 68-41	Decal, Warning Engine Sym
6	532 18 04-32	Decal, DBA
7	532 40 03-89	Decal, Read Owner's Manual
8	532 19 43-02	Decal, V-Belt Sch.
9	532 14 08-37	Decal, Parking Brake
10	532 18 21-66	Decal, Cut Finger
11	532 40 82-03	Decal, Strg. Wheel

KEY NO.	PART NO.	DESCRIPTION
12	532 43 12-21	Decal, Hood RH/LH
13	532 40 82-88	Decal, Hood Side Panel
14	532 40 11-46	Decal, Warning Serv/Fire
15	532 14 50-05	Decal, Caution, Battery
--	532 40 82-87	Decal, Fender
--	532 16 25-98	Decal, Drawbar
--	532 13 83-11	Decal, Handle Lft Height Adj.
--	532 40 09-01	Manual, Operator's, Euro.
--	532 42 63-19	Manual Parts

WHEELS & TIRES

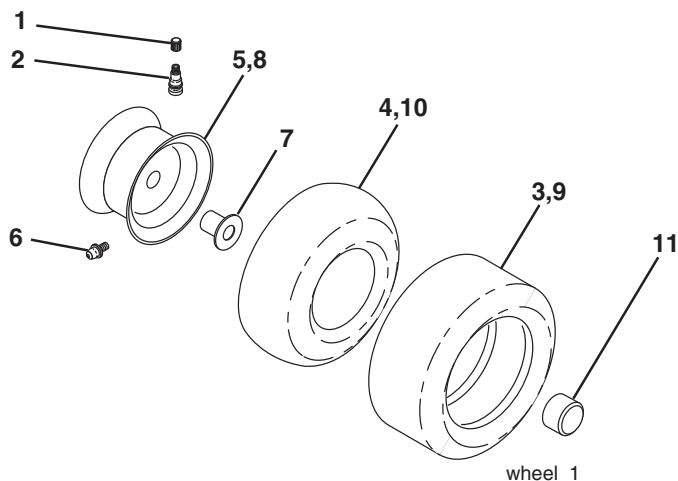

KEY NO.	PART NO.	DESCRIPTION
1	532 05 91-92	Cap, Tire valve
2	532 06 51-39	Stem, Valve
3	532 12 41-57	Tire, Front
4	532 05 99-04	Tube, Front (Service item only)
5	532 12 51-21	Rim assembly, 6" Front
6	532 12 49-57	Fitting, Grease (Front wheel only)
7	532 12 49-59	Bearing, Flange (Front wheel only)
8	532 12 51-22	Rim assembly, 8" Rear
9	532 12 39-69	Tire, Rear
10	532 12 49-26	Tube, Rear (Service item only)
11	532 17 50-39	Cap, Hub Axle
--	532 14 43-34	Sealant, Tire (10 oz. Tube)

NOTE: All component dimensions given in U.S. inches
1 inch = 25.4 mm

REPAIR PARTS

TRACTOR - MODEL NUMBER M11597 (96011023406), PRODUCT NO. 960 11 02-34
MOWER DECK

KEY NO.	PART NO.	DESCRIPTION	KEY NO.	PART NO.	DESCRIPTION
1	532 19 25-56	Mower Housing Assembly	149	532 16 58-98	Retainer Spring Yellow
2	872 14 05-06	Bolt Carriage 5/16-18 x 3/4	150	819 09 12-10	Washer 9/32 x 3/4 x 10 Ga.
3	532 13 80-17	Bracket Asm Fr. Sway Bar	152	532 19 32-35	Clutch Cable 38"/46"
4	532 19 25-68	Bracket Deck Sway Bar 38"/42"	158	817 72 04-08	Screw Hex Thd Cut 1/4-20 x 1/2
5	532 12 46-70	Retainer Spring	185	532 18 82-34	Head Asm Cable Clutch
6	532 17 80-24	Bar Sway Deck	186	817 49 06-44	Screw Hex Wsh Thdrol 3/8-16 x 2-3/4
7	873 80 05-00	Nut Lock Hex w/Ins. 5/16-18 unc	187	532 19 34-12	Keeper Belt
8	532 19 30-03	Bolt 3/8-24 x 1.25 Gr. 8	188	532 16 58-91	Bolt Carriage Idler
11	532 19 39-57	Blade Mower	189	532 19 25-59	Stand, Brake
13	532 19 28-72	Shaft Assembly, Mandrel, Vented	190	532 19 25-60	Arm, Brake
14	532 18 72-81	Housing, Mandrel, Vented	191	532 19 25-61	Spacer, Brake
15	532 11 04-85	Bearing, Ball, Mandrel	193	532 19 34-13	Keeper Belt Rh Mandrel
18	872 14 05-05	Bolt Rdhd Sqnk 5/16-18 x 5/8	194	532 19 41-05	Guard Brake
19	532 13 28-27	Bolt, Shoulder	195	819 13 32-10	Washer
20	532 40 00-95	Baffle Vortex Front	205	817 49 04-16	Screw 1/4 - 20 x 1.0077
21	873 68 05-00	Nut	206	819 09 14-16	Washer 9/32 x 7/8 x 16 Ga.
23	532 19 25-57	Bracket, Mower Deflector	208	817 67 06-08	Screw 3/8 - 16 x 1/2
24	532 10 53-04	Cap, Sleeve	209	532 42 29-65	Cover Deck Asm LH
25	532 19 70-26	Spring, Torsion, Deflector	210	532 42 30-11	Cover Deck RH
26	532 11 04-52	Nut, Push	214	532 19 37-82	Bolt/Washer Asm 5/16-18
27	532 40 16-18	Shield, Deflector	304	532 42 17-89	Shield, Side LH
29	532 13 14-91	Rod, Hinge	305	532 42 17-90	Shield, Side RH
30	532 17 39-84	Screw Thdrol.	306	532 42 30-62	Palnut 1/4
31	532 18 76-90	Washer, Spacer	--	532 19 25-58	Brake Assembly (Includes Stand, Arm and Guard Components)
32	532 15 35-32	Pulley, Mandrel	--	532 19 28-70	Mandrel Assembly (Includes Housing, Shaft and Shaft Hardware Only - Pulley Not Included)
33	532 40 02-34	Nut, Toplock	--	532 19 36-46	Replacement Mower, Complete
36	532 13 14-94	Pulley, Idler, Flat			
37	532 19 31-98	Pulley Idler Flat			
40	873 68 06-00	Nut, Crownlock 3/8-16 unc			
45	532 12 47-88	Retainer Spring			
46	532 13 77-29	Screw			
55	532 13 38-40	Idler Arm Assembly			
56	532 16 57-23	Spacer, Retainer			
67	532 10 69-32	Knob			
68	532 19 32-14	V-Belt			
72	532 19 32-16	Spring Brake Return			
89	819 13 13-11	Washer 13/32 x 13/16 x 11 Ga.			
107	532 13 35-02	Spacer Retainer			
108	532 13 35-03	Stiffener, Idler Arm			
122	532 41 01-89	Rod, Brake LH			
123	532 41 01-90	Rod, Brake RH			
144	532 19 34-14	Keeper Belt Idler Tension			
148	532 16 90-22	Spring Return Idler			

NOTE: All component dimensions given in U.S. inches
1 inch = 25.4 mm

REPAIR PARTS

TRACTOR - MODEL NUMBER M11597 (96011023406), PRODUCT NO. 960 11 02-34
MOWER LIFT

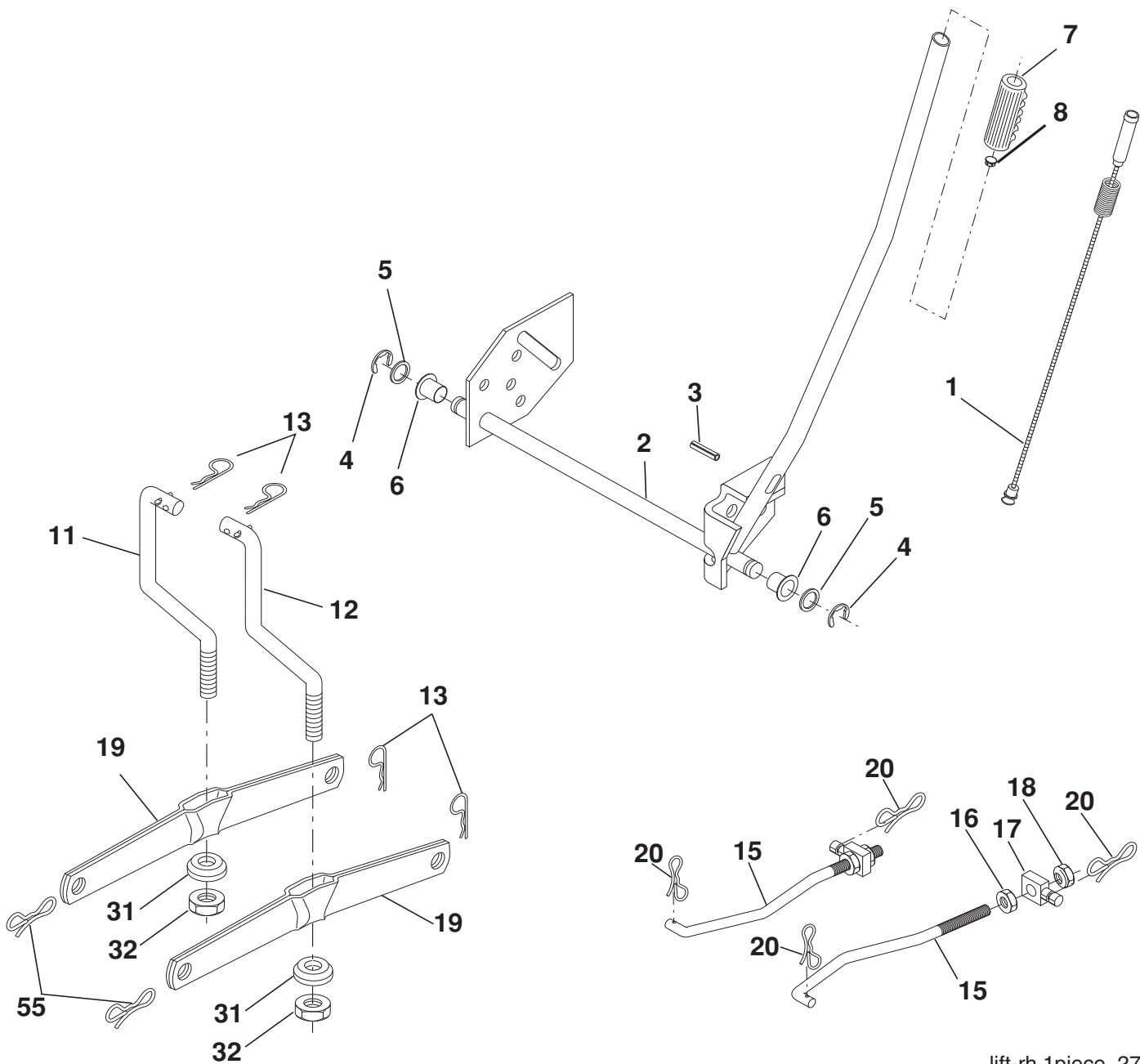

lift-rh.1piece_27

KEY NO.	PART NO.	DESCRIPTION
1	532 40 49-81	Plunger Asm Lift Lvr
2	532 15 94-71	Shaft Asm Lift RH
3	532 10 57-67	Pin Groove
4	812 00 00-02	E Ring #5133-62
5	819 21 16-21	Washer 21/32 x 1 x 21 Ga
6	532 12 01-83	Bearing Nylon Blk 629 Id
7	532 10 94-13	Grip Handle Bicycle Matte Blk
8	532 12 45-26	Button Plunger Black
11	532 13 98-65	Link Lift LH Fixed Length
12	532 13 98-66	Link Lift RH Fixed Length
13	532 12 46-70	Retainer Spring
15	532 17 32-88	Link Front

KEY NO.	PART NO.	DESCRIPTION
16	873 35 08-00	Nut Jam Hex 1/2-13 unc
17	532 17 56-89	Trunnion
18	873 80 08-00	Nut Lockw/Wsh 1/2-13 unc
19	532 13 98-68	Arm Suspension Rear
20	532 19 42-09	Retainer, Spring
31	532 16 98-65	Bearing Pvt Lift
32	873 54 06-00	Nut Crownlock 3/8-24
55	532 19 42-08	Bow Tie Lock

NOTE: All component dimensions given in U.S. inches
1 inch = 25.4 mm.

SERVICE NOTES



McCULLOCH